

PACIFIC SCIENCE PHYSICS EQUIPMENT OPERATION AND EXPERIMENT GUIDE

COMPLETE ZEEMAN EFFECT APPARATUS

P67501

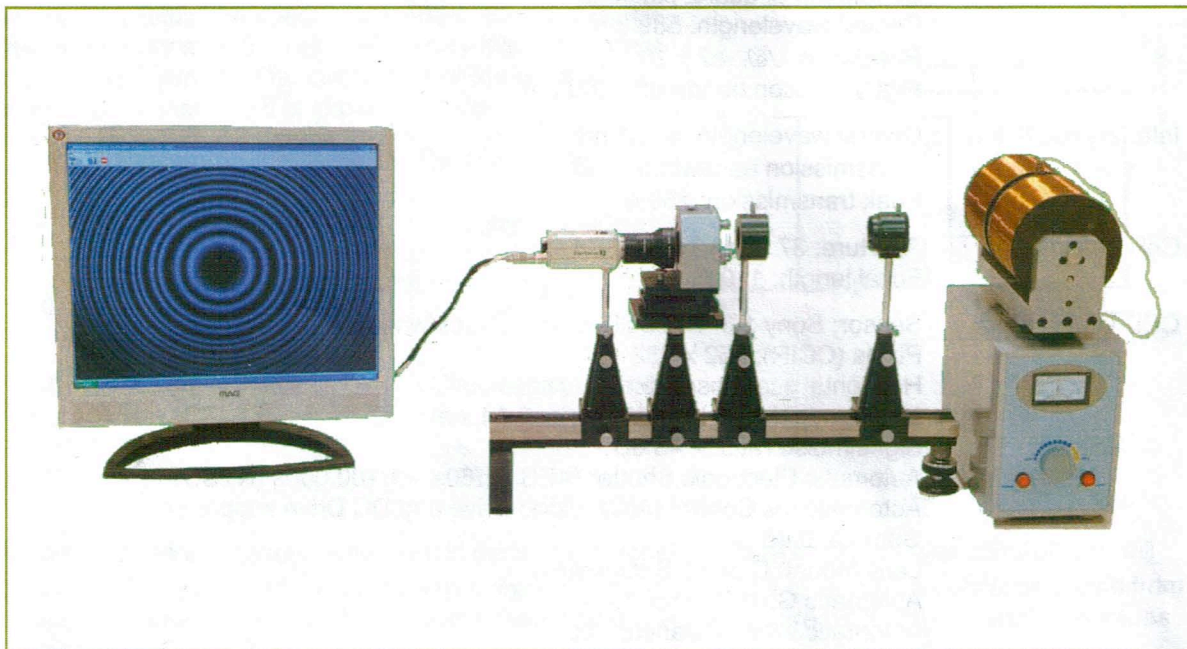

1. Introduction

This apparatus was designed for modern physics labs at universities and colleges. It demonstrates the influence of a magnetic field on light emitted in a gas discharge, the Zeeman Effect, and shows the quantum nature of light and the behavior of electrons in atoms emitting light. Using the software supplied with the apparatus, students can collect data and analyze it to determine the value of e/m for bound electrons in an atom. A mercury discharge lamp is placed between the pole pieces of a powerful electromagnet and the green emission line at 546.1 nm is selected by an interference filter. The resulting light beam is passed to a high resolution, fixed separation Fabry-Pérot étalon whose interference pattern is captured by a CCD camera and passed to a computer, where special software analyzes the changes observed as the magnetic field is varied. Light can be observed both parallel and transverse to the magnetic field, and filters allow the polarization states of the emitted lines to be investigated. The Fabry-Pérot étalon can also be used for other experiments requiring high resolution spectroscopy.

The determination of e/m from optical measurements requires the student to be familiar with optics, electromagnetism and quantum physics. The design of this Zeeman Effect Apparatus, integrating the optical, imaging and computer analysis features, makes it much easier to use than traditional Zeeman Effect setups and requires less demanding measuring skills, allowing students to focus more on the underlying physical principles of the phenomena being observed.



2. Specifications

Lamp:	Mercury discharge lamp, slim design, powered A.C., 1500V _{p-p} , 5W Observed emission line: 3S_1 (6s7s) \rightarrow 5P_2 (6s7s) at 546.1 nm
Electromagnet:	Built-in current-controlled power supply, 90V DC, 0-5 – 1.4 A, with analog ammeter Magnet rotatable 90° for transverse or longitudinal viewing Maximum magnetic field at lamp position: 1.3 T
Fabry-Pérot Etalon:	Aperture: 40 mm Separation of quartz plates: 2.0 mm Central wavelength: 589.3 nm Resolution $\lambda/\delta\lambda$: $\geq 2 \times 10^5$ High reflection bandwidth: 100 nm
Interference Filter:	Central wavelength: 546.1 nm Transmission bandwidth: ≤ 10 nm Peak transmission: $\geq 50\%$
Collimating Lens:	Aperture: 37 mm Focal length: 110 mm
CCD Camera:	Sensor: Sony 1/3" HD CCD sensor (black/white) Pixels (CCIR): 752 x 582 Horizontal scan resolution: 600 lines Minimum detectable illumination: 0.1 Lx at f/1.2 Signal/noise ratio: > 48 dB Automatic Electronic Shutter (AES): 1/60s – 1/100,000s (NTSC) Automatic Iris Control (AIC): Video Drive and DC Drive supported Gamma: 0.45 Lens Mount: C and CS supported Automatic Gain Control: Yes Automatic White Balance: Yes Backlight Compensation: On/Off Synchronization: Internal, negative Video output: 1V _{p-p} into 75 Ω , BNC connector Input voltage: 12V DC Power consumption: 1.65W
Environmental:	Operating limits: 0 - 40° C (32 - 104°F), relative humidity $\leq 85\%$ Choose a location free from vibration or electromagnetic interference
Power Input:	110VAC/60 Hz, 190W

3. Basic Theory

When a light-emitting atom is subjected to a magnetic field, its emission lines are split into multiple components at slightly shifted wavelengths. This phenomenon is known as the Zeeman Effect, named for Pieter Zeeman, who first observed the phenomenon in 1896 in Leyden (Netherlands), and received the 1902 Nobel Prize in Physics for his discovery.

The atomic magnetic moments along a given axis are quantized, and assume defined orientations when subjected to a magnetic field. In these orientations, the atoms' bound electrons have different energies than in the zero-field state, the amount of the difference depending on which of the several allowed orientations an electron assumes. Each energy level is therefore now split into several sub-



Pieter Zeeman



levels, and light-emitting transitions between levels which were all of the same energy at zero field regardless of the electron orientation have now become a series of different, orientation-dependent transitions at slightly differing energies. This is experienced as a “splitting” of the observed spectral line on imposing a magnetic field.

The transitions which can be observed in a magnetic field are governed by the selection rule for the magnetic quantum number M , namely that for allowed transitions $\Delta M = 0$ or ± 1 , and also by the state of polarization of the emitted light. Linearly polarized light is observed in a direction transverse to the magnetic field, while circularly polarized light is emitted parallel to the field.

In this apparatus, the spectral line observed is the green line of mercury at 546.1 nm, which splits into nine components (see Figure 1). The distribution of the observable lines in a magnetic field is shown in Table 1.

ΔM	Perpendicular to Field	Parallel to Field
+1	Linearly polarized - σ^+	Circularly polarized - σ^+
0	Linearly polarized - π	No light
-1	Linearly polarized - σ^-	Circularly polarized - σ^-

Table 1

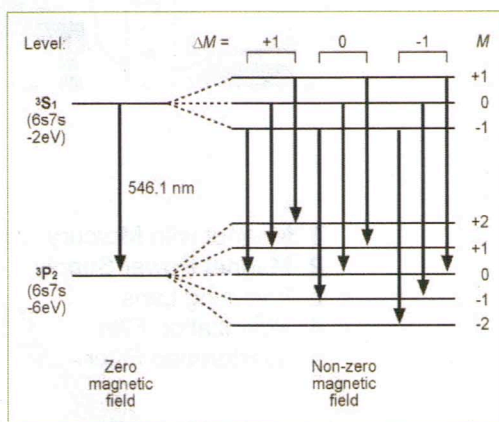

Figure 1

When the lines are observed perpendicular to the magnetic field direction, all nine components will be visible. They include three π polarized lines and six σ polarized ones. The polarizations arise from the relative orientations of the magnetic field and the vibration directions of the emitted light, as illustrated by Figure 2:

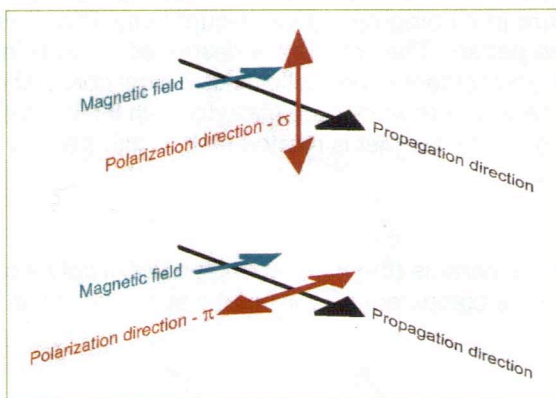

Figure 2

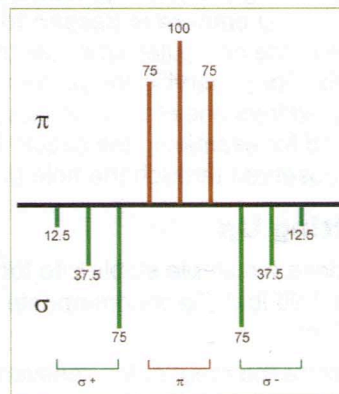

Figure 3

The three π lines are located in the center of the pattern and are the most intense. The six σ lines are weaker and located on the outside of the pattern. Figure 3 illustrates this arrangement. Overlapping of the closely spaced lines makes observation and measurement difficult. However, since all the lines are linearly polarized, a polarizing filter can be used to block the six σ lines, leaving the three central π lines more clearly visible for measurement. Rotation of the filter enables the existence and polarization state of the six σ lines to be confirmed.

4. The Zeeman Effect Apparatus

Figure 4 shows the arrangement of the components of the Zeeman Effect Apparatus.

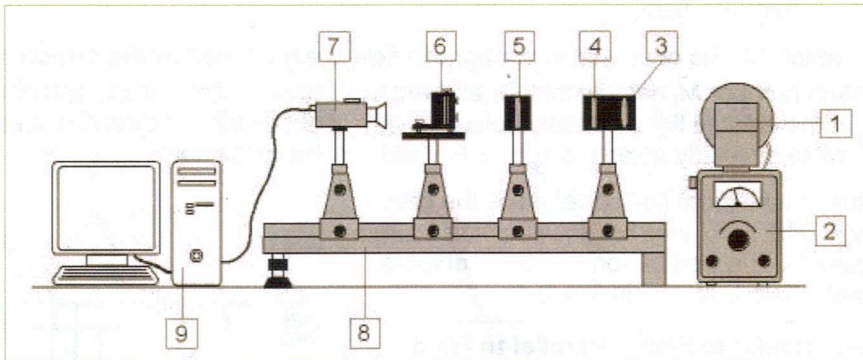

Figure 4

- | | |
|----------------------------|------------------------------|
| 1 Magnet with Mercury Lamp | 6 Fabry-Pérot Etalon |
| 2 Magnet Power Supply | 7 CCD Camera |
| 3 Focusing Lens | 8 Optical Bench with Riders |
| 4 Polarization Filter | 9 Computer with Capture Card |
| 5 Interference Filter | |

The slim, low pressure mercury lamp is mounted in a support at the center of the poles of the electromagnet (1), whose yoke can be rotated 90° on top of the magnet power supply (2), which also energizes the mercury lamp. Light from the lamp is focused by a lens (3) and passes successively through a rotatable polarization filter (4) and an interference filter (5), which selects the green line at 546.1nm, before falling on a Fabry-Pérot étalon (6). The étalon generates an interference pattern of concentric rings which is observed by a black and white CCD camera (7). The optical elements (3) through (7) are mounted on an optical bench (8) for easy adjustment; careful alignment of the optical arrangement significantly improves the interference pattern and the accuracy of the results. The signal from the CCD camera is passed to a capture card in a computer (9, user-supplied). Proprietary software in the computer analyzes the interference pattern. The software is described in detail in the Appendix. For observing the pattern in a direction parallel to the magnetic field, a steel core rod can be removed from one of the magnet's pole pieces and a quarter wave plate (included with the apparatus) is inserted for examining the circularly polarized light. The magnet is rotated so that the mercury light can be observed through the hole in the pole piece.

5. Setting Up

- Choose a suitable stable site for setting up the apparatus (the magnet and power supply weigh about 90 lbs). To accommodate the setup and the computer you will need a space of about 2 m x 0.75 m.
- Arrange the magnet for transverse viewing.
- **DO NOT CONNECT THE MAGNET POWER SUPPLY TO AN AC OUTLET YET – HIGH VOLTAGE IS PRODUCED AT THE LAMP TERMINALS WHEN THE POWER SUPPLY IS ENERGIZED.**
- Set up the optical bench with the end with the adjustable foot about 10 cm from the magnet power supply and with its axis in line with the center of the magnet where the lamp will be located.
- Fit the mercury lamp into the clip between the pole pieces, pushing it down until the shoulder on the lamp support rests on the top of the clip. Rotate the lamp so that the clear window is perpendicular to the magnet axis. Connect the lamp's supply leads to the two binding posts located on the lower arm of the magnet yoke (see Figure 5).



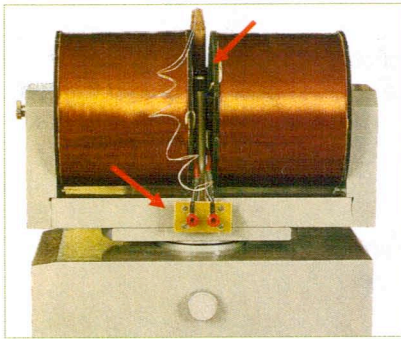

Figure 5

- Mount the four riders onto the optical bench and fit the lens and polarization filter, étalon support table, interference filter, and CCD camera onto the riders as shown in *Figure 4*.
- Position the riders on the bench with the support rods at approximately the following separations:
 - Front of magnet yoke base – lens/polarizing filter: 27 cm
 - Lens/polarizing filter - interference filter: 6 cm
(as close as possible)
 - Interference filter – étalon support table: 10 cm
 - Étalon support table - CCD camera – 15 cm

- Make sure that the lens in the lens/polarization filter combination faces the magnet.
- The interference filter appears blue-green when viewed from one side and yellow when viewed from the other. For best results, the blue-green side should face the magnet.

- Carefully adjust the heights of the lens/polarization filter, interference filter, and CCD camera so that their centers are aligned with the center of the mercury lamp and clamp them in place. Fix the adjusted heights with the positioning rings on the support rods (see *Figure 6*). This allows the optical elements to be easily removed and replaced accurately.

- As a rough guide for initial positioning, when the optical axes of the various elements are collinear and aligned with the lamp center, the bottoms of the positioning rings are at the following distances below the bottoms of their respective elements:

Lens/polarizing filter: 95 mm

Interference filter: 97 mm

Étalon table: 34 mm

CCD camera: 98 mm

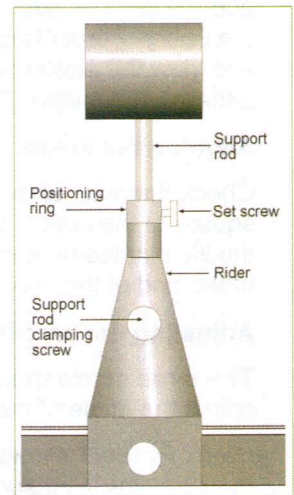

Figure 6

- Fit the video capture card into the computer and connect the camera power and video cables. (See detailed instructions in the Appendix)
- Place the Fabry-Pérot étalon on the support table, oriented with the three plate adjusting screws on the lamp side and the single tilt adjustment screw on the camera side. Make sure the étalon is centered on the optical axis and square to it. Do not adjust the plate adjustment screws yet.
- Turn the computer on, insert the software CD into the computer, and copy the software file onto the computer's hard drive.
- Run the Zeeman Effect software and connect the software to the camera signal (see Appendix). Adjust the focus and aperture of the camera to view the pattern at the back of the Fabry-Pérot étalon.
- Connect the magnet power supply to an AC outlet and press the power switch. Allow the mercury lamp to warm up (about 5 minutes)

6. Optimizing the Interference Pattern

The procedure for determining e/m involves measuring the diameters of concentric circles which differ only slightly. Precise adjustment of the optical setup to yield properly centered and undistorted circular fringes is important for obtaining an accurate result. To obtain a good interference pattern, attention should be paid to the following factors:

- Even illumination of the Fabry-Pérot étalon.
- Careful positioning of the various optical elements so they are centered along the optical axis of the setup and correctly aligned about their vertical axes.
- Precise parallelism of the Fabry-Pérot étalon mirrors.
- Optimal focus and aperture of the camera.

Even illumination of the Fabry-Pérot étalon:

The knob on the top of the interference filter housing arrows is the interference filter to be rotated about a vertical axis in order to match the filter to the wavelength of the light used. To ensure that the Fabry-Pérot étalon is evenly illuminated, first remove the camera and its rider from the bench and view the étalon closely from the rear. Move your eye around until you locate the interference pattern. Now adjust the angle of the interference filter until the entire pattern is evenly illuminated.

Aligning the setup:

Check that the centers of the lamp, lens, filter, and étalon are collinear and that each element is its square to the optical axis. Adjust the position of the lens along the bench to maximize the size of the illuminated area of the étalon. View the étalon from the rear and adjust the position and height of the end of the bench so that the interference pattern is centered in the étalon mirror.

Adjusting the parallelism of the Fabry-Pérot étalon plates:

The three screw mechanisms on the front of the Fabry-Pérot étalon adjust the angle of the front mirror with respect to the fixed rear mirror.

(Note: Figure 7 shows a cross-section of one of the adjusting screw mechanisms. Pressure is applied to the adjustable mirror by a pressure ring. The pressure is adjusted by compression of a spring via a thumbscrew on a fixed stud. The thumbscrew has a range of about 5 mm. **DO NOT OVER-TIGHTEN THE THUMBSCREW. DO NOT ATTEMPT TO ADJUST THE STUD WITH A SCREWDRIVER.** These actions could cause serious damage to the étalon.)

The mirrors can be made accurately parallel using a parallax procedure. View the étalon from the rear once more and move your eye from side to side and up and down. Since in general the mirrors will not already be parallel, you will see the center of the pattern appear to move with your eye. Using small adjustments of one screw mechanism at a time, regulate the angle between the mirrors until the center of the pattern no longer appears to move with your eye. The mirrors are now parallel. You should see the rings appear to be evenly bright and of equal width and sharpness all the way round. Using the two rear adjustment thumb-screws (see Figure 8), adjust the angle of the étalon housing until the center of the pattern is at the center of the mirror. The pattern is now ready for imaging. (Note: the thumbscrew on top of the étalon housing fixes & releases the étalon for rotation in its housing.)

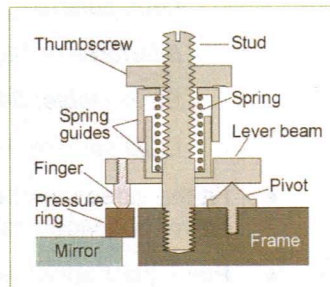

Figure 7



Figure 8



Adjusting the camera:

Replace the camera on the optical bench, connect it to an AC outlet, start the software and connect the camera to the software (see Appendix). Open up the iris with the aperture ring so that an image appears on the monitor. The Fabry-Pérot fringes are located at infinity, so the camera focus ring should be adjusted for distant viewing. The camera can now be moved along the bench as close to the back of the étalon as possible to exclude disturbing ambient light and increase the contrast in the monitor image. Optimize the image by adjusting the focus and aperture rings as necessary.

7. Recording the Patterns

Viewing the patterns—transverse viewing

Figure 9 shows the appearance of the patterns observed on the monitor for viewing transverse to the magnetic field in various states.

- Figure 9a shows the initial appearance of the pattern with no imposed magnetic field.
- Turn the potentiometer on the magnet power supply all the way counterclockwise, then press the “MAGNET” button (Figure 10)
- Rotate the potentiometer clockwise to increase the magnet current until an easily-visible splitting of the circular fringes is seen on the monitor.

Note: Do not run the magnet with the potentiometer in the yellow zone (Figure 10) for long periods of time to avoid overheating the magnet coils.

- Rotate the polarizer mounted behind the lens until a pattern like Figure 9b is observed. This shows the full range of Zeeman-split lines emitted in the transverse direction.
- Continue to rotate the polarizer until the triple fringes shown in Figure 9c are seen. These are the strong π -polarized components that will be used for measurement.
- Rotating the polarization filter by a further 90° yields the pattern shown in Figure 9d. These fringes arise from the σ -polarized components and are noticeably less intense.

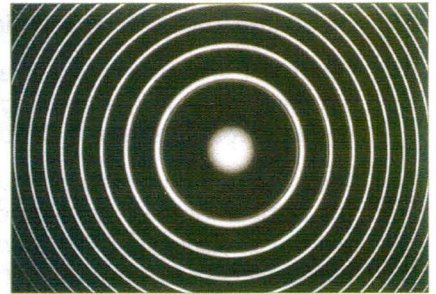

Figure 9a

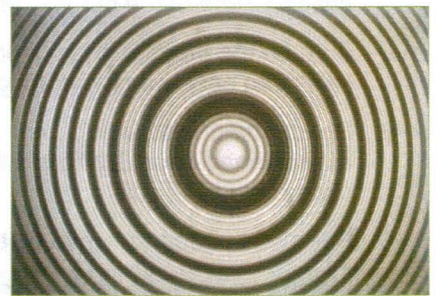

Figure 9b

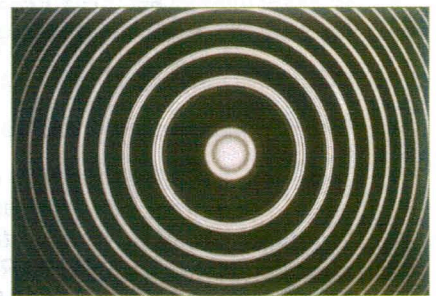

Figure 9c

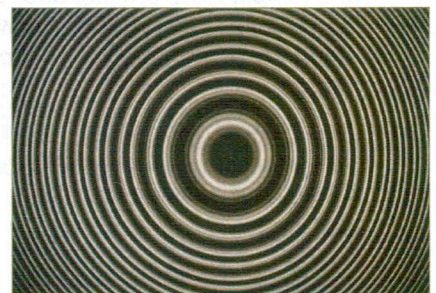

Figure 9d

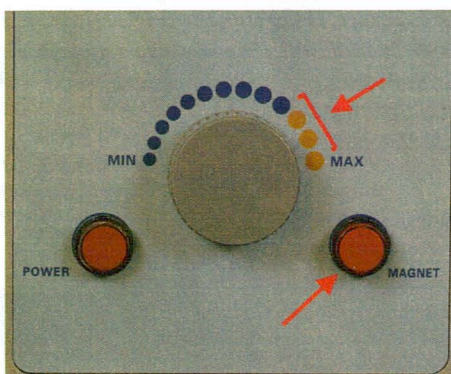

Figure 10

Viewing the patterns—parallel viewing

- Make sure the magnet current is turned off.
- Remove the iron core from the right hand pole piece of the magnet by pulling out on the thumbscrew (Figure 11a). This opens a narrow hole through the pole piece for parallel viewing.
- Rotate the lamp in its socket to direct the light from the window through the hole in the pole piece.
- Insert the quarter wave plate into the hole in the pole piece (Figure 11b)
- Release the magnet yoke arresting screw on the side of the magnet power supply (Figure 11c) and swing the entire magnet assembly through 90° so that the light from the lamp is directed along the optical bench.
- View the pattern on the computer monitor. Adjust the angle of the magnet and the position of the optical bench as necessary to obtain as clear and bright a pattern as possible. (*The beam is narrow and well collimated where it exits the pole piece, so this adjustment needs some care. You may need to adjust the position of the lens and/or the angle of the étalon housing to obtain the best image.*) Tighten the magnet yoke arresting screw.
- Turn on the magnet and observe the pattern as before. The zero-field pattern splits into only two sets of fringes.
- Rotate the quarter wave plate and observe that each of the sets of fringes is extinguished once during a full revolution, confirming the circular polarization states listed in Table 1.
- Remove the quarter wave plate and observe that rotating the polarizer has no effect.

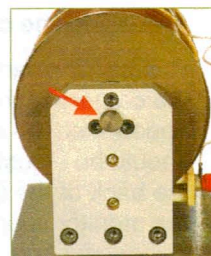

Figure 11a

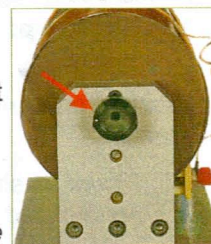

Figure 11b

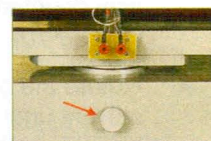

Figure 11c

Saving the transverse pattern for analysis

- With the magnet set up for transverse viewing, adjust the polarizer to obtain a clear pattern of only the triple fringe set of the π -polarized emission as in Figure 9c.
- Adjust the magnet current to a suitable value to yield clearly separated fringes.
- Using a gaussmeter, measure the magnetic field strength at the location of the lamp.
- *Note: The field strength can be obtained approximately from a field strength vs. current calibration curve, but a more accurate value is obtained by a direct measurement at the time the pattern is recorded. Carefully remove the lamp from its bracket to allow the gaussmeter probe to be inserted into the gap. BE CAREFUL NOT TO TOUCH THE BINDING POSTS OF THE LAMP POWER SUPPLY OR THE LAMP LEADS. Carefully re-insert the lamp into its bracket after the measurement, making sure that it is inserted all the way until the shoulder rests on the bracket and that the window faces towards the optical bench.*
- The Zeeman Effect software allows you to save the captured pattern in either BMP or JPG format. Select *Action(A)*, then choose the appropriate “Save As...” option for the format you prefer (see Figure 12).

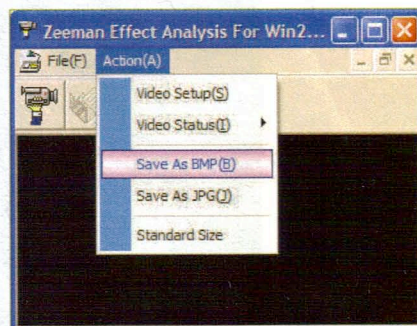

Figure 12



- The standard “Save As” dialog box will appear. Navigate to the location where you want to save your patterns for measurement, name your file, and click on the “Save” box.

8. Analysis

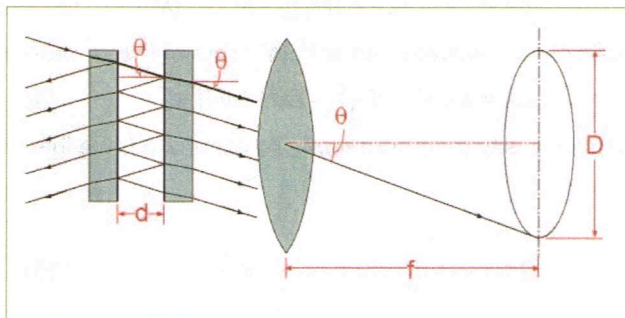

Figure 13

Figure 13 shows a schematic of the ray paths in the Fabry-Pérot étalon and the focused image at the camera.

The medium between the two mirrors is air with a refractive index of 1, so if the separation of the mirrors is d , the optical path difference between two adjacent light beams at an angle θ is

$$\Delta = 2d\cos\theta.$$

For constructive interference with light of wavelength λ , $\Delta = k\lambda$, and so

$$\Delta = 2d\cos\theta = k\lambda$$

At the center of the pattern, $\theta = 0$ and $\cos\theta = 1$. Since $\cos\theta$ decreases with increasing angle from the center, the order of interference k is highest at the center of the pattern, and subsequent rings going outward are $k-1$, $k-2$, etc.

The rays exiting the étalon are parallel and when they are focused at a distance f from the camera lens, the incident angle θ is preserved.

The diameter D of an interference ring is $2f.\tan\theta$ (Figure 13) and for small values of θ at the center of the pattern, $\tan\theta = \theta$ so $\theta = D/2f$. Approximating for $\cos\theta$ at small angles, we obtain for the k^{th} order ring

$$2d(1 - D_k^2/8f^2) = k\lambda \quad (1)$$

If the spectral line under study at frequency ν is produced by an electron transition between two energy levels E_2 and E_1 , we have

$$h\nu = E_2 - E_1$$

In an external magnetic field B , the potential energy of magnetic dipole moment of an atom is:

$$\Delta E = Mg.(eh/4\pi m).B \quad (2)$$

where e and m are the charge and mass of the electron, h is Planck's constant, M is the magnetic quantum number and g is the Landé factor.

The additional potential energy shifts the energy levels E_1 and E_2 to $E_1 + \Delta E_1$ and $E_2 + \Delta E_2$ so the new frequency of the transition, ν' is obtained from

$$h\nu' = (E_2 + \Delta E_2) - (E_1 + \Delta E_1)$$



The shift $\Delta\nu$ in the frequency of the line is

$$\Delta\nu = \nu - \nu' = (1/h)(\Delta E_1 - \Delta E_2)$$

Substituting for ΔE from equation (2) and converting from frequency to wavelength:

$$\Delta\lambda = (-\lambda^2/c)\Delta\nu = (M_2g_2 - M_1g_1) \cdot (\lambda^2/4\pi c) \cdot (e/m) \cdot B \quad (3)$$

From equation (1) we obtain for the wavelength shift in terms of the k^{th} order ring:

$$\Delta\lambda = \lambda - \lambda' = (D_k'^2 - D_k^2) \cdot (d/4f^2k) \quad (4)$$

The effective value of f cannot easily be determined. To eliminate f , we introduce the $(k-1)^{\text{th}}$ interference ring.

From equation (1):

$$2d(1 - D_{k-1}^2/8f^2) = (k - 1)\lambda \quad (5)$$

Subtracting (1) from (5)

$$d/[4f^2(D_{k-1}^2 - D_k^2)] = \lambda \quad (6)$$

Solving equation (6) for f^2 and substituting into equation (4):

$$\Delta\lambda = (\lambda/k) \cdot (D_k'^2 - D_k^2)/(D_{k-1}^2 - D_k^2) \quad (7)$$

For the rings close to the center, where $\cos \theta \approx 1$, $k \approx 2d/\lambda$. Substituting into (7) gives:

$$\Delta\lambda = (\lambda^2/2d) \cdot (D_k'^2 - D_k^2)/(D_{k-1}^2 - D_k^2) \quad (8)$$

Combining equations (3) and (8) and rearranging gives an expression for e/m in terms of measurable quantities:

$$e/m = (2\pi c/dB) \cdot [1/(M_2g_2 - M_1g_1)] \cdot (D_k'^2 - D_k^2)/(D_{k-1}^2 - D_k^2) \quad (9)$$

9. Analysis of the saved pattern

Analysis is performed on the π -polarized triplet fringe set that corresponds to the transitions for which $\Delta M = 0$. Table 2 details the magnetic quantum numbers and Landé factors for these transitions:

	Upper State, 3S_1	Lower State, 5P_2	Δ
M	1	1	0
	0	0	0
	-1	-1	0
g	2	3/2	n/a
Mg	2	3/2	-1/2
	0	0	0
	-2	-3/2	+1/2

Table 2

Comparing the values of $\Delta(\text{Mg})$ for these transitions with the corresponding term in equation (3), it is clear that the wavelength of the central fringe remains unshifted while the outer two are displaced symmetrically by an amount $1/2 \cdot (\lambda^2/4\pi c) \cdot (e/m) \cdot B$.



This allows us to use the diameters of two central lines in adjacent orders as D_k and D_{k-1} , and the diameters of the outer lines as D_k' in equation (9) to determine e/m .

The software analyzes rings from three consecutive orders and averages to obtain values for e/m .

The designations used in the software for the ring diameters are shown in Figure 14.

With mouse clicks, the operator sets three points on each of three rings in three consecutive orders, and the software draws matching rings, identifies their diameters, and calculates the average differences of squares, then derives e/m .

The differences of squares displayed by the software are as follows:

$$\Delta d_1 = (d_{k-1}^2 - d_k^2 + d_{k-2}^2 - d_{k-1}^2)/2$$

$$\Delta d_{21} = (d_{k1}^2 - d_{k2}^2 + d_{k-11}^2 - d_{k-12}^2 + d_{k-21}^2 - d_{k-22}^2)/3$$

$$\Delta d_{22} = (d_{k3}^2 - d_{k2}^2 + d_{k-13}^2 - d_{k-12}^2 + d_{k-23}^2 - d_{k-22}^2)/3$$

Δd_1 corresponds to the term $(D_{k-1}^2 - D_k^2)$ in equation (9), while Δd_{21} and Δd_{22} correspond to $(D_k'^2 - D_k^2)$ for the $\Delta(Mg) = +1/2$ and $\Delta(Mg) = -1/2$ rings respectively.

Details of the installation and operation of the software are given in the Appendix.

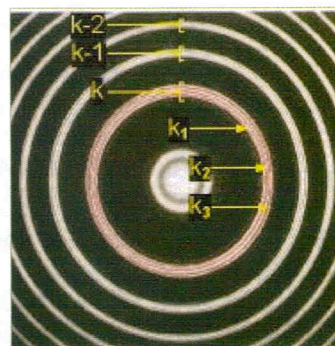

Figure 14

10. Further suggestions

- The software program can also be used to analyze the wavelength shift for the σ -polarized emission in the transverse direction and the circularly polarized light in the parallel direction. In these cases, the software will calculate e/m using only two orders of interference.
- The linearity of $\Delta\lambda$ in B can be verified by recording patterns at different field strengths, using the software to calculate the differences of squares, and calculating values of $\Delta\lambda$ from equation (8).

11. Maintenance and storage

- The Zeeman Effect Apparatus should be used in a dry clean room with a good ventilation. Cover the unit when it is not in use.
- Lubricate the surface of the optical bench periodically to prevent it from rusting.
- When not in use, the Fabry Perreault at Tom should be stored in a sealed container with a desiccator. Replace the desiccator periodically to prevent mold formation.
- Do it not touch any optical part with your hand. To remove dust or dirt, use a photographic lens brush, or blow the dust off with "canned air". Do not use compressed air from an airline as this frequently contains oil droplets, which will contaminate the surface of the optical parts. Stubborn dirt may be removed by gently cleaning the surface with a cotton ball soaked in a 1:1 mixture of denatured alcohol and ether.
- To prolong the life of the mercury lamp avoid turning it on and off frequently.
- When applying the magnetic field, increase the current slowly and avoid leaving the potentiometer in the zone marked by yellow dots for long periods. This will avoid excessive heat generation in the magnet coils.



Appendix

Installing the Video Capture Card

The video capture card supplied with the Zeeman Effect Apparatus fits into a PCI expansion slot in a PC-based desktop computer and processes the incoming video signal from the CCD camera for display on the computer's monitor. *Figure A1* shows the video capture card and identifies its principal parts.

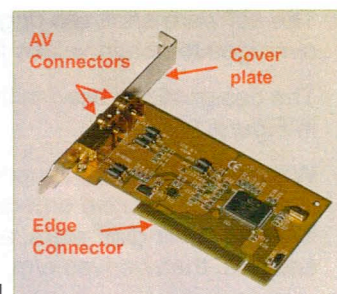

Figure A1

- The card contains components that can be damaged by static electric discharge. **BE CAREFUL NOT TO TOUCH THE SOLDER CONNECTIONS ON THE PRINTED CIRCUIT BOARD, THE MOUNTED COMPONENTS, OR THE CONTACTS OF THE EDGE CONNECTOR.**



Figure A2

- If possible, wear a wrist grounding strap while handling the card. Make sure to discharge any accumulated static charge on your hands by touching a grounded metal object, such as the computer case, before picking up the video capture card.

- The internal arrangement of computers varies considerably with the model. The accompanying figures show a common arrangement, but your computer may differ from this. Make sure to carefully identify the PCI slot and the connections for the cover plate before installing the video capture card.

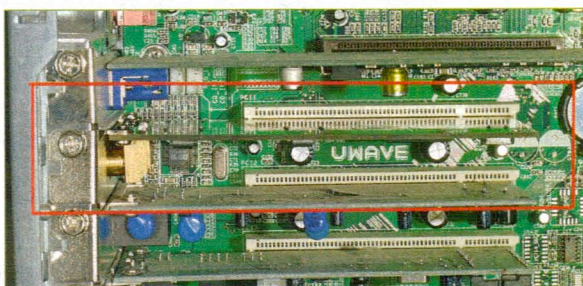

Figure A3

- Before opening the computer's case, disconnect the power cord from the AC outlet. Also disconnect any other external devices that could be a source of voltage to the computer.

- Open the computer's case following the manufacturer's directions and locate an empty PCI slot. *Figure A2* shows an empty PCI slot with the blank metal cover removed.
- Remove the retaining screw and the blank cover. Keep the screw for securing the card
- Install the video capture card into the PCI slot as shown in *Figure A3*. Hold the card by the edges and do not touch the edge connectors. Make sure the tongue on the card's metal cover fits into the appropriate slot in the computer's chassis and that the edge connector is properly seated in the socket.

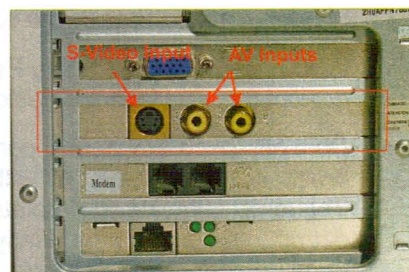

Figure A4

- Secure the card in place by attaching the retaining screw.
- Close the computer's case and re-attach any disconnected cables.
- *Figure A4* shows the rear of the computer with the video capture card installed. The two AV input sockets are identified. The CCD camera may be connected to either socket. The corresponding port is selected in the software (see below).



Using the CCD Camera



Figure A5

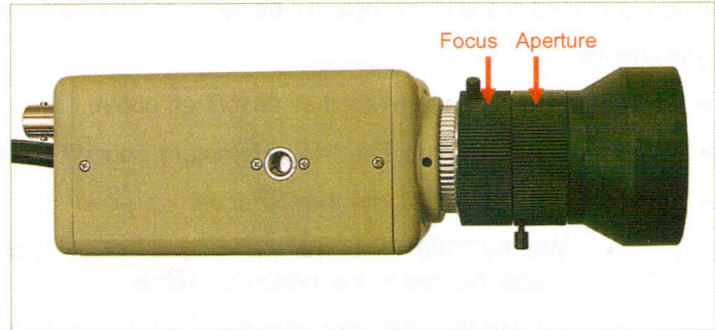

Figure A6

- The camera mounting rod screws into the threaded socket on the bottom of the camera.
- The camera has a built-in power cord that plugs directly into a standard 110VAC outlet.

Figure A5 shows the rear of the CCD camera. The BNC socket for the video connector is indicated. A small LED to the right of the video connector illuminates when the camera is powered on. Connect the "video out" socket to one of the two AV inputs on the video capture card in your computer using the BNC/RCA cable supplied.

- The two switches below the video connector control the Automatic Electronic Shutter (AES) and the backlight compensation (BLC). The AES should be selected and the BLC should be off (both switches in the left position).
- The potentiometer, 4-pole socket and switch to the right of the video connector are all concerned with an optional Automatic Iris, which is not required or supplied. The positions of the potentiometer and switch are unimportant.
- Figure A6 shows the top view of the camera. The two adjusting rings for aperture and focus of the lens are indicated. Also visible is a black set screw immediately behind the silver-colored lens mount ring. This screw fixes the lens mount ring in place. If a focus of a nearby object cannot be achieved, loosening this screw allows the position of the lens mount ring to be adjusted to correct the problem. This will not be necessary for viewing the Zeeman Effect interference pattern.
- The interference rings of the Fabry-Pérot pattern are localized at infinity, so the focus ring should initially be set so that distant objects are in focus.
- It is good practice to keep the aperture set at minimum while adjusting the camera and to open the aperture for viewing the pattern. Since the pattern is located at infinity, the camera can be moved close to the Fabry-Pérot étalon to exclude ambient light once the apparatus adjustments have been made.

The Zeeman Effect Analysis Software

System Requirements

CPU: Celeron III at 1.0GHz, equivalent or better

Available RAM: 64MB

Available disk space: 1GB

Operating systems supported: Win 98, Me, 2000, Xp



DirectX: Version 8.0 or higher

Recommended monitor settings: 32-bit color, 1024 x 768 pixels

Installation

- Install the video capture card as described above.
- Turn on the computer. The "New Hardware Found" dialog box will appear.
- Insert the software CD into the CD drive
 - **Win 98/2000:** Open the *Video Card Driver* folder and install the files in the *Win98200* folder.
 - Restart the computer after the driver has been successfully installed. Open the *setupfile* folder and select *SETUP.EXE* to install the software.
 - *Notes: If the computer cannot find the hardware after the video capture card is installed, the problem could be improper installation of the video capture card. Remove it from the PCI slot and reinstall it securely, or use a different PCI slot. You will find the following new items under "sound, video and game controllers" on the Device Manager after the video capture card has been installed successfully:*
Win98: 10Moons Audio Capture Driver, 10Moons Video Capture Driver
Win2000: 10Moons SDK-2000 WDM Audio Capture, 10Moons SDK WDM Video Capture, 10Moons SDK-2000 WDM Crossbar
 - **Win Xp:** copy the folder *package* from the CD-ROM onto your chosen location on your hard drive. Open the folder and select *reg.exe*, then click on *regocx.dll*. A dialog box will show the installation of the seven files in *reg.exe*.
 - Select *project1.exe* to run the program.

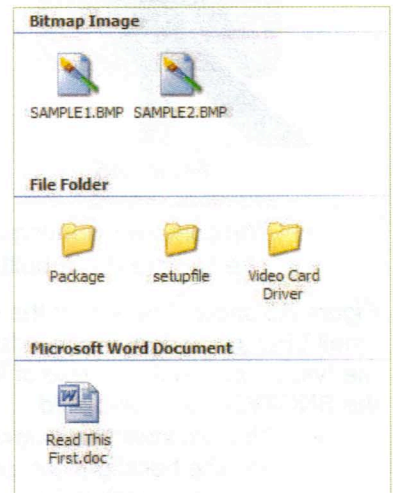

Software CD contents

Connecting to the Video Capture Card

- Start up the software and instruct the software to connect to the video capture card by clicking on the camera icon or selecting *Connect* under the *Video Card(V)* menu.

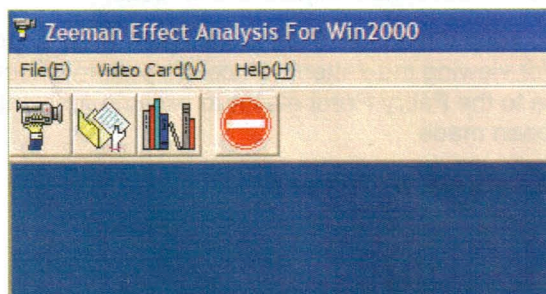

Opening menus

- Generally, the software will not be correctly set up to recognize the video capture card and you will receive the message "Card don't connect!". Click *OK*. The menu options will change.



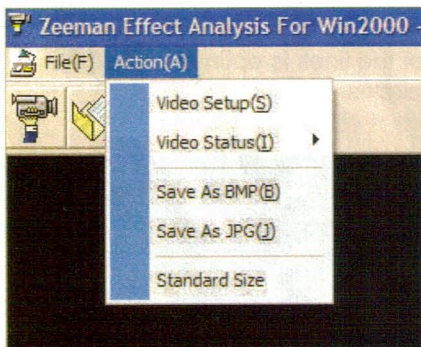

Video menu

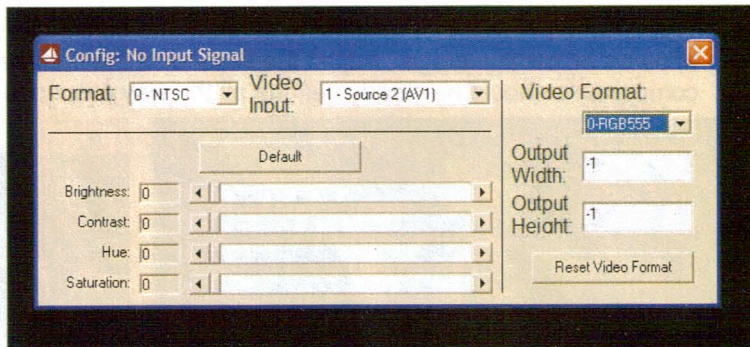

Video configuration dialog

- On the *Action(A)* menu select *Video Setup(S)*. The video configuration dialog box will appear.
- Adjust the *Format*, *Video Input* and *Video Format* selections as follows:

Format: 0 - NTSC

Video Input: 1 - Source x (AVx) (choose to match the card input where you connected the video cable during installation)

Video Format: 0-RGB555 or 1-RGB24

Click *Reset Video Format* and close the dialog box.

- The image from the video camera should now appear on the monitor. The menu option *Standard Size* on the *Action(A)* menu sets the image on the monitor to the standard 640x480 pixels. The *Video Status(I)* option turns the live image on and off.

Recording an Image for Analysis

The procedure for adjusting the image and observing interference patterns is described in section 7 above. The software allows images to be saved in either BMP or JPG format. The software can analyze images in either format. The desired image is saved by selecting the appropriate option from the *Action(A)* menu.

Procedure for Analyzing an Image

- If you are observing a live image on the monitor, select *Close* from the *File(E)* menu.
- Select *Open File(O)* from the *File(E)* menu, or click on the folder icon, then navigate to the location where you have stored in the file you wish to analyze. Open the file. The image appears together with a new menu bar and an empty results box.

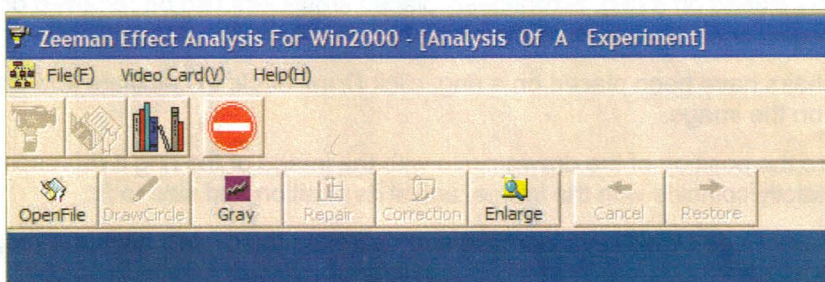
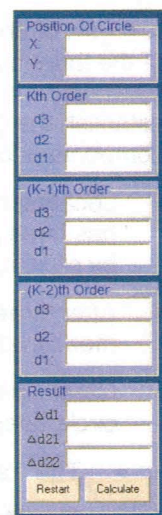
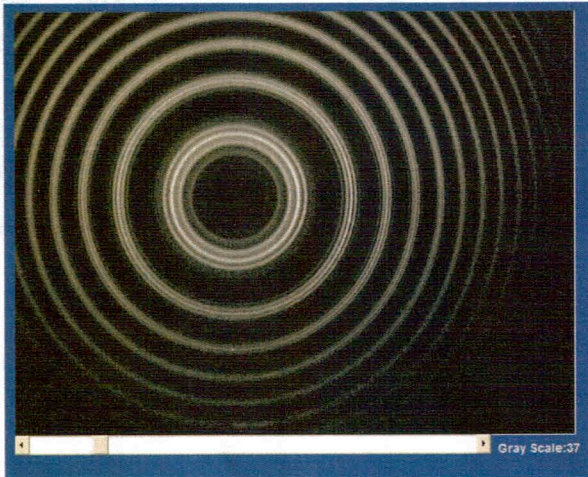

Image analysis menus



Results box

- The *Gray* icon initiates a function to improve the contrast in the image for easier analysis. A slider appears below the image. Adjust the slider until the contrast of the lines is optimal—all of the components should be clearly defined all the way around the circles.



The Gray function

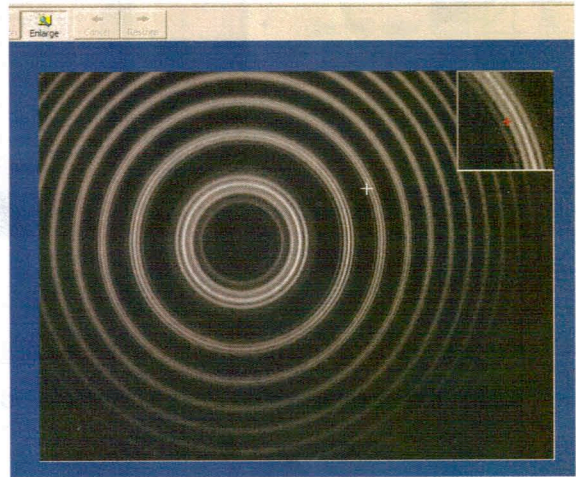

The Enlarge function

- The *Enlarge* function opens a subsidiary window in the top right corner of the image, showing a magnified view of the area around the position of the crosshairs. This is very useful in positioning the crosshairs precisely for measuring the positions of the rings.
- The *Repair* function applies an algorithm to reduce noise in the image. In most cases, it will not be necessary to use this function, since the contrast in the black-and-white image is usually sufficient, especially if ambient light has been excluded from the area between the étalon and the camera lens. If needed, the function should be used with care as it is easy to render the image unusable by excessive repair (see example).

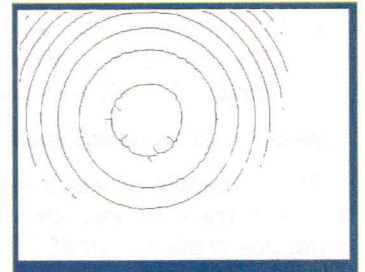

Excessive repair

Analysis of an image requires the measurement of four sets of interference rings. In each set, each of the three components is located by placing locating crosshairs at three points approximately 120° apart on the rings. The first set of rings, most conveniently the innermost complete order, is used to establish the center point of the pattern. The remaining three sets establish the diameters of the components of the k^{th} , $(k-1)^{\text{th}}$, and $(k-2)^{\text{th}}$ order fringes.

- Locating crosshairs are placed on the image by left clicking the mouse after the main crosshair has been precisely placed on a ring. Erroneously placed crosshairs can be removed or restored by clicking the *Cancel* or *Restore* icon on the menu bar.
- After three crosshairs have been placed on a ring, click *Draw Circle* to calculate and draw the measured circle on the image.
- Carefully compare the position of the drawn circle with the image of the ring it represents. If the circle does not exactly coincide with the image, adjust its position and size to fit:
 - The *Page Up* and *Page Down* keys increase and decrease the circle's diameter respectively
 - The *Up*, *Down*, *Left* and *Right Arrow* keys nudge the circle in their respective directions



- When all three components of the first set of fringes have been drawn, click the *Correction* icon on the menu bar and answer *No* to the Hint question. The center of the circle system will be calculated and marked by a crosshair and the center's pixel coordinates will be entered into the results box.

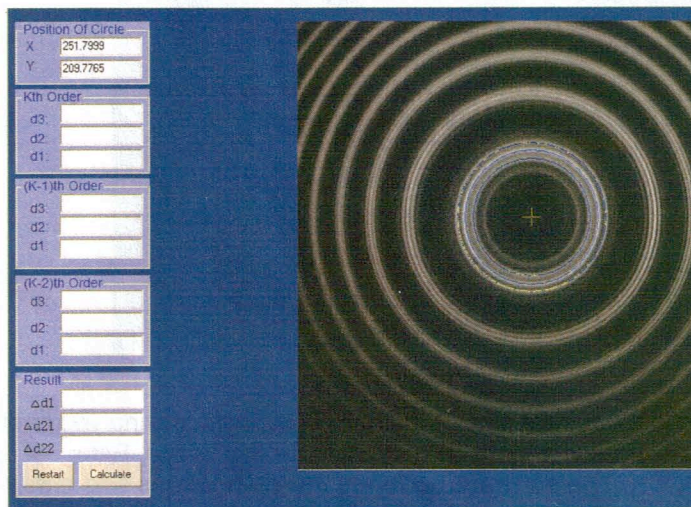

Center established

- Now proceed to mark out the first of the component rings of the k^{th} interference order with locating crosshairs. After you select *Draw Circle*, a dialog box appears, asking you to identify which ring you are marking.

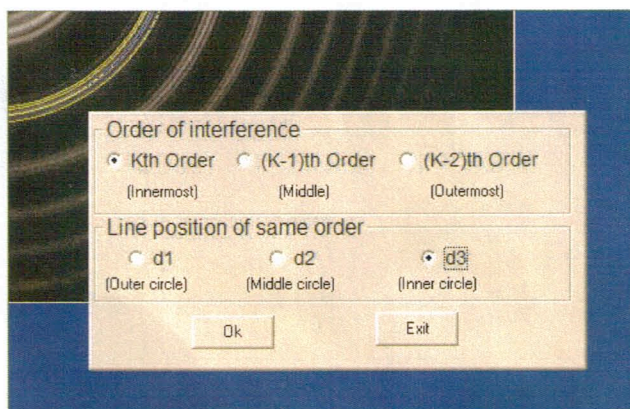

Ring identification dialog

- Make the appropriate selections for the order and line position and click *Ok*, then *Exit*.
- A new box appears with the diameter of the line you have just measured and its identification entered.
- Proceed to measure the remaining lines of the k^{th} order in the same way, then repeat the process for the $(k-1)^{\text{th}}$ and $(k-2)^{\text{th}}$ interference orders.
- When you are done, you should have all nine components of the three orders listed in the results sub-box.

Order	Line ...	Diam...
K	3	256
K	2	264
K	1	274

Results sub-box

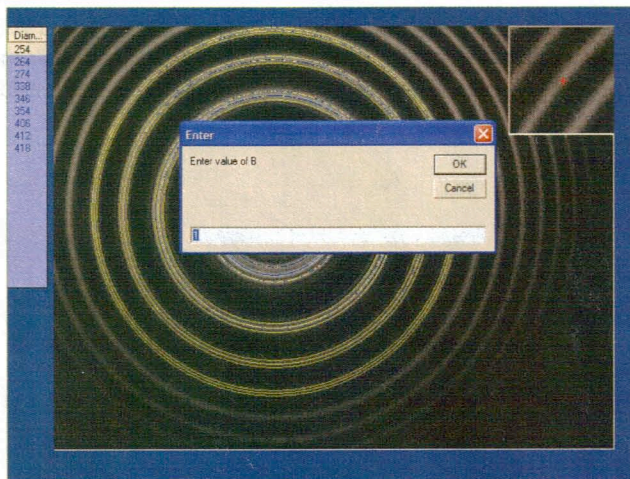

Field strength dialog

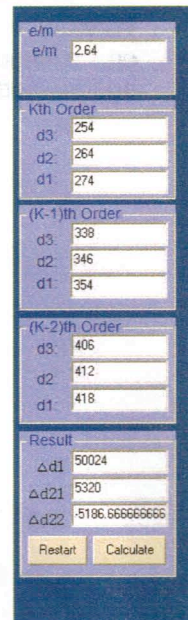

Results box

- Click on *Calculate* in the results box. A dialog box appears, asking you to enter the measured value of the magnetic field strength for this image. Enter the value in Tesla and click *OK*. The software performs the calculations and enters the results in the results box.
- To reset the software for a new and image analysis, click *Restart* in the results box.
- To exit the software, click *Exit* on the *File(E)* menu or select the *Exit* icon.

Copyright Notice

This P67501 Complete Zeeman Effect apparatus Operation and Experiment Guide is copyrighted and all rights are reserved. Permission is granted to all non-profit educational institutions to make as many copies of this work as they need as long as it is for the sole purpose of teaching students. Reproduction of this work by anyone for any other purpose is prohibited.

© Pacific Science Supplies, Inc., 2008

